

**RoHS COMPLIANT**

DESCRIPTION CONTROL			
REV	DESC	DATE	APP
A	FIRST RELEASE	2013/04/10	
B	CHANGE P/N	2013/04/25	
C	CHANGE CARTON SPEC	2013/04/29	
D	CHANGE DRAWING	2013/05/03	
D-1	CHANGE DRAWING	2013/05/07	
E	CHANGE DRAWING	2013/06/25	

HOUSING 10P

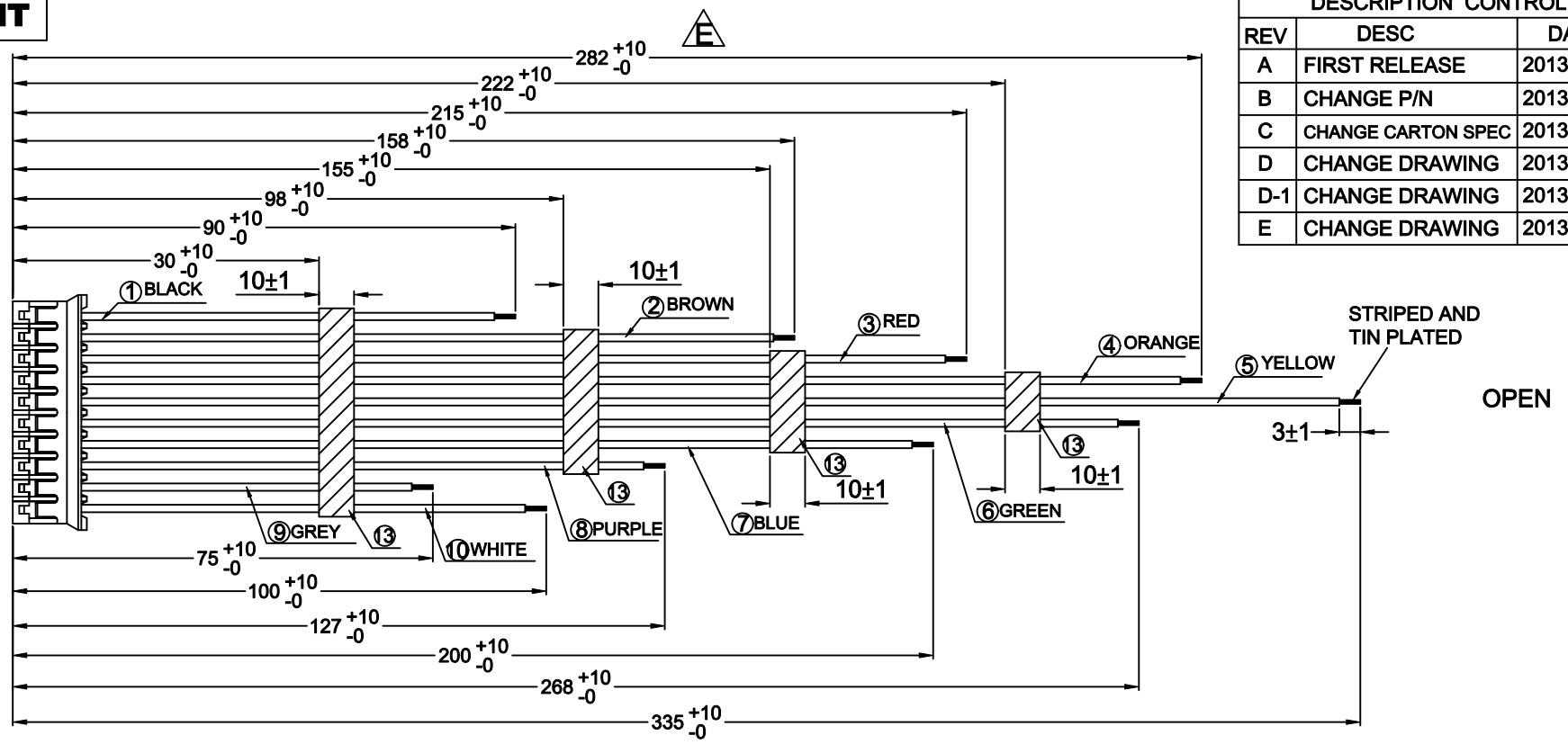
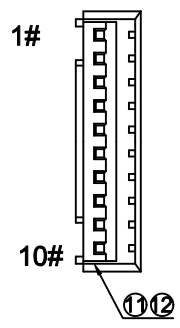

13	4		BLACK HEAT SHRINK TUBE.
12	10	B0398	TERMINAL:PITCH2.0MM.
11	1	B0397	HOUSING:PITCH2.0MM 10PIN PHR-10.
10	1	F0133	UL1007 24AWG WHITE JUMP WIRE .
9	1	F0132	UL1007 24AWG GREY JUMP WIRE .
8	1	F0131	UL1007 24AWG PURPLE JUMP WIRE .
7	1	F0130	UL1007 24AWG BLUE JUMP WIRE .
6	1	F0051	UL1007 24AWG GREEN JUMP WIRE .
5	1	F0129	UL1007 24AWG YELLOW JUMP WIRE .
4	1	F0108	UL1007 24AWG ORANGE JUMP WIRE .
3	1	F0106	UL1007 24AWG RED JUMP WIRE .
2	1	F0107	UL1007 24AWG BROWN JUMP WIRE .
1	1	F0011	UL1007 24AWG BLACK JUMP WIRE .
ITEM	QTY	PART NUMBER	DESCRIPTION

**NOTES:**

- PIN ASSIGNMENT SEE TO WIRE LIST.
- ELECTRICAL TEST CONDITION:
  - 100 %OPEN,SHORT & MISWIRE TEST,
  - INSULATOR RESISTANCE:20 Mohm MIN DC 300V 0.01sec..
  - CONTACT RESISTANCE:1ohm MAX.
  - ALL ENDS NEED TO BE STRIPED 3MM AND TIIN PLATED.
  - EACH INDIVIDUAL SHRINK SLEEVE.10MM HAS BEEN MENTIONED.



UNIT	mm	Projection			Seconn International Enterprise Co., Ltd.	
DRAWN	Huang shenggen	SCALE	1:1	TITLE		
CHECK, BY		REV	E	HOUSING 10PIN TO OPEN		
APP, BY		DATE	2013/04/10	TOLERANCES		
DWG NO.	SE-S-0074		X.= ±	.X= ±	.XX= ±	.XXX= ±
PART NO.	0411-000-003		SHEET	1/2	SIZE	A4

**RoHS COMPLIANT**

DESCRIPTION CONTROL			
REV	DESC	DATE	APP
A	FIRST RELEASE	2013/04/10	
B	CHANGE P/N	2013/04/25	
C	CHANGE CARTON SPEC	2013/04/29	
D	CHANGE DRAWING	2013/05/03	
D-1	CHANGE DRAWING	2013/05/07	
E	CHANGE DRAWING	2013/06/25	

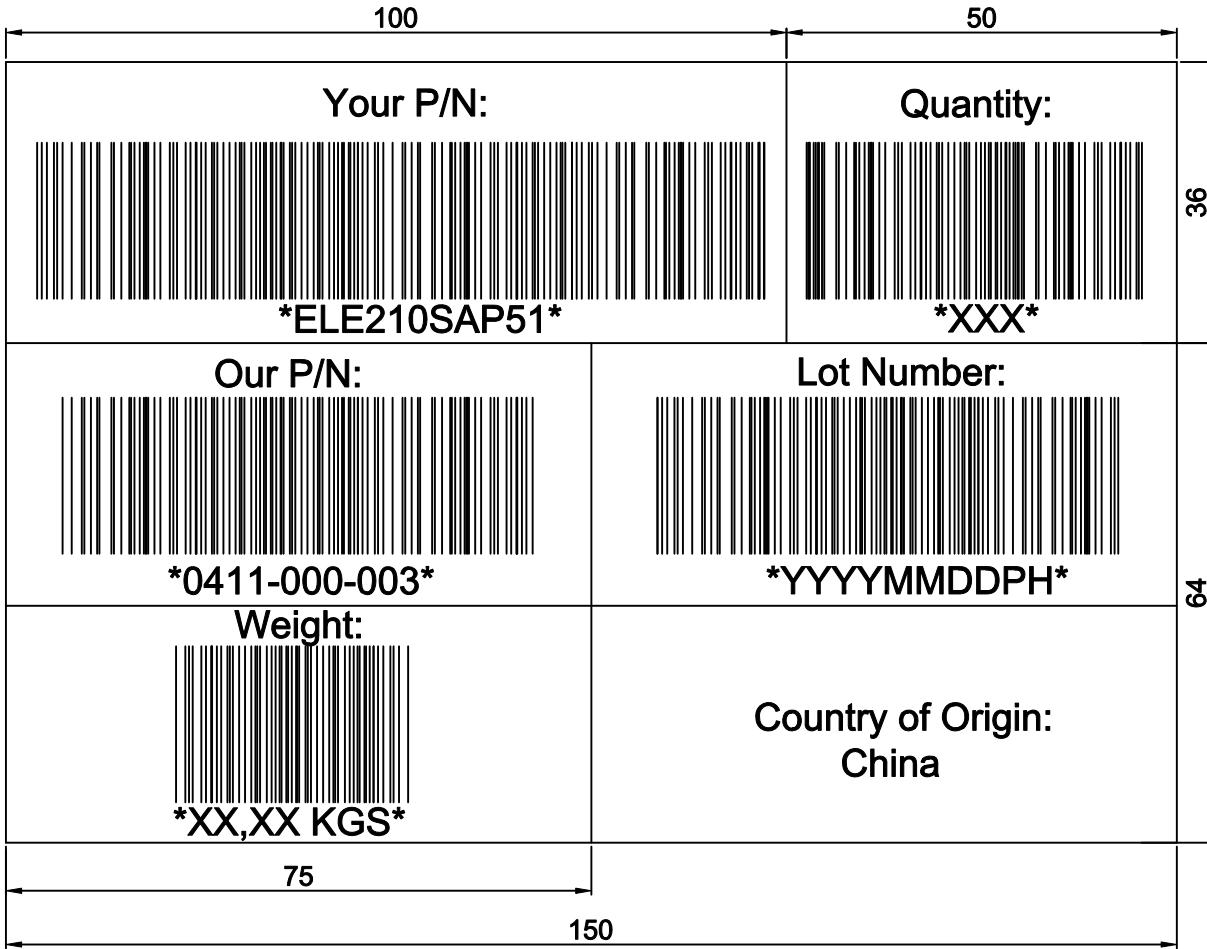

**CARTON LABEL**

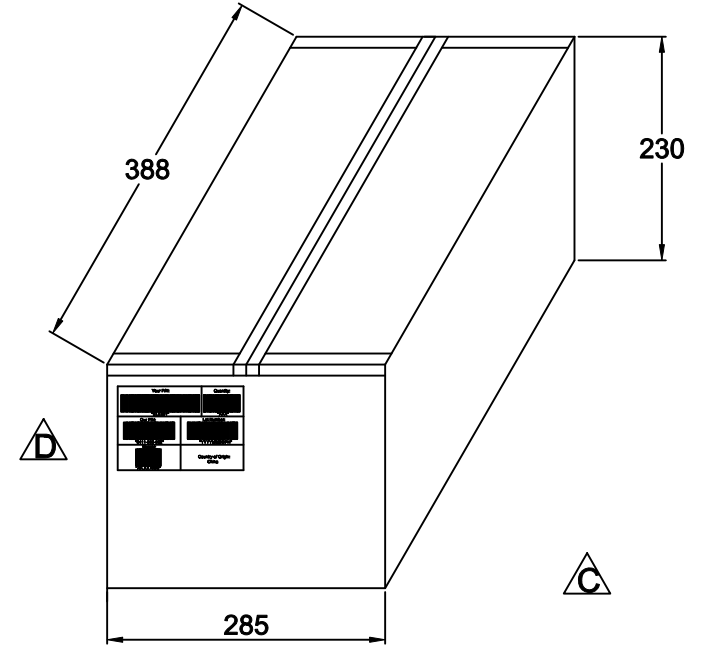

**CARTON**

Font type:Ariel 5mm  
Barcode type:code 3 of 9  
Barcode size:20mm  
(Except"Weight"10mm)

Lot number:YYYYMMDDH  
YYYY=year  
MM=month  
DD=day  
P=product with this production date,  
First P/N="A",next P/N=B,etc.\*  
H:Lot size,First 10K="A",next 10K="B",  
etc of this P/N.

UNIT	mm	Projection			Seconn International Enterprise Co., Ltd.			
DRAWN	<i>Huang shenggen</i>	SCALE	1:1	TITLE				
CHECK,BY		REV	E	HOUSING 10PIN TO OPEN				
APP,BY		DATE	2013/04/25	TOLERANCES				
DWG NO.	SE-S-0074			X.= ±	.X= ±	.XX= ±	.XXX= ±	
PART NO.	0411-000-003			SHEET	2/2	SIZE	A4	